

TS-1



Tortilla Strip Slicing Machine



FOODTOOLS
Industry Leaders in Portion Control

TS-1

Average Speed:

Up to 60-80 Tortillas per Minute

Function:

This model is an economical machine used to quickly slice tortillas into strips. Tortillas are loaded into the gravity fed machine via the ramp at the top and stainless steel roller cutters slice the strips. The sliced product can drop into a box, tray, bag, or onto a conveyor. This is a great machine for any tortilla or pita production line needing to cut up to 38,000 tortillas per shift.

Benefits

- Achieve a return on investment through labor savings and improved portion quality and consistency
- Perfectly portion tortilla products every time no matter who is slicing
- Portion up to 4750 tortillas per hour
- Virtually eliminate the possibility of returned product due to uneven slices (miss-cuts).
- Small and compact design can be placed on a table and is perfect for locations with limited space
- Reliable and durable equipment backed by manufacturer's warranty



Tortilla Strip Slicing Machine

FoodTools Corporate Office

Santa Barbara, CA U.S.A.
805.962.8383
877.836.6386

FoodTools Central

South Haven, MI U.S.A.
269.637.9969
800.644.2377

FoodTools United Kingdom

Ongar, Essex U.K.
44.1277.364869

FoodTools Asia

Zhuhai, Guangdong China
86.756.2127528

sales@foodtools.com

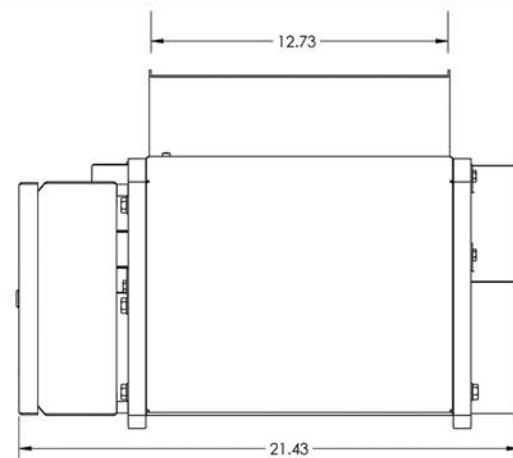
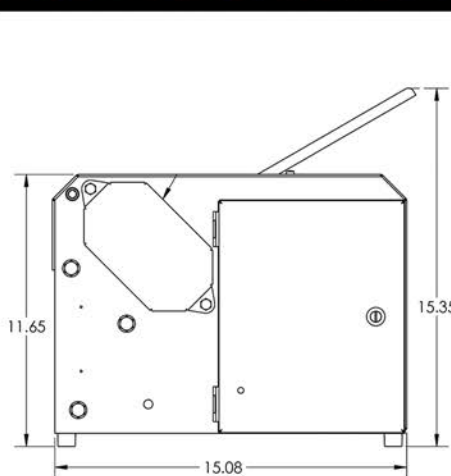

Power:

Electric 120V, 60 cycle, 1 Phase, 20A

Product Size Ranges:

8" (20 cm) - 12" (30 cm) Diameter

Portion Size Ranges

.25" (.635 cm) and Larger Strips

FoodTools machines are manufactured with heavy duty anodized aluminum, stainless steel, and ultra-high molecular weight plastic. The equipment is designed for complete wash down requirements in production facilities.

Specifications are subject to change and are dependent on the product portioned or additional accessories to standard equipment.
© FoodTools - 11/2019

www.foodtools.com

FOODTOOLS
Industry Leaders in Portion Control